

# ALBERT MODELL

Meticulously crafted miniature models for demanding collectors

Photo : Patrick Sambourg



Tapps / Tanpps freight wagons

**Novelty 2025**  
H0 scale

Novelty 2025

# Tapps / Tanpps freight wagons

The model belongs to the family of Tapps and Tanpps type wagons, also known as the T90 series, which includes the well-known "Transengrais" wagons.

These wagons have been built since 1983 by various manufacturers, such as CFMF, Fauvet-Girel, ANF, and AFR, in multiple versions. The study of these wagons takes into account all existing variants from eras IV, V, and VI (SNCF, CTC, France Wagons, Ermewa).

All versions are offered, including those intended for sugar transport, while respecting their specific differences. The wagons are fitted with either welded or molded Y25 bogies, depending on the model. Two different registrations are available for each variant.

These wagons feature many detailed parts, such as the CG markings on the sides, the roof control rods, and all the control chains.

Expected release date: end 2025 / beginning 2026 | Recommended retail price: 54€



Photo : Frédéric Poupelain



Photo : Raphaël Gulli

Nouveauté 2025

# Wagons de marchandises Tapps / Tanpps

Ce modèle appartient à la famille des wagons de type Tapps et Tanpps, désignés sous le code T90, qui inclut notamment les célèbres wagons « Transengrais ».

Ces wagons ont été construits à partir de 1983 par divers fabricants tels que CFMF, Fauvet-Girel, ANF et AFR, en plusieurs exemplaires. L'étude de ces wagons prend en compte toutes les variantes existantes des époques IV, V et VI (SNCF, CTC, France Wagons, Ermewa).

Nous proposons toutes les versions, y compris celles destinées au transport de sucre, en respectant leurs spécificités. Les wagons sont montés sur des bogies Y25, soudés ou moulés selon les modèles. Deux immatriculations différentes sont disponibles pour chaque variante.

Ces wagons comportent de nombreux détails, tels que la CG sur les flancs, les tringles de commande du toit, ainsi que l'ensemble des chaînes de commande.

**Date de sortie prévue : fin 2025 / début 2026 | Prix de vente conseillé : 54€**



Photo : Patrick Sambourg



Photo : Patrick Sambourg

**6 versions are produced** / *6 versions sont produites*

## **T84**

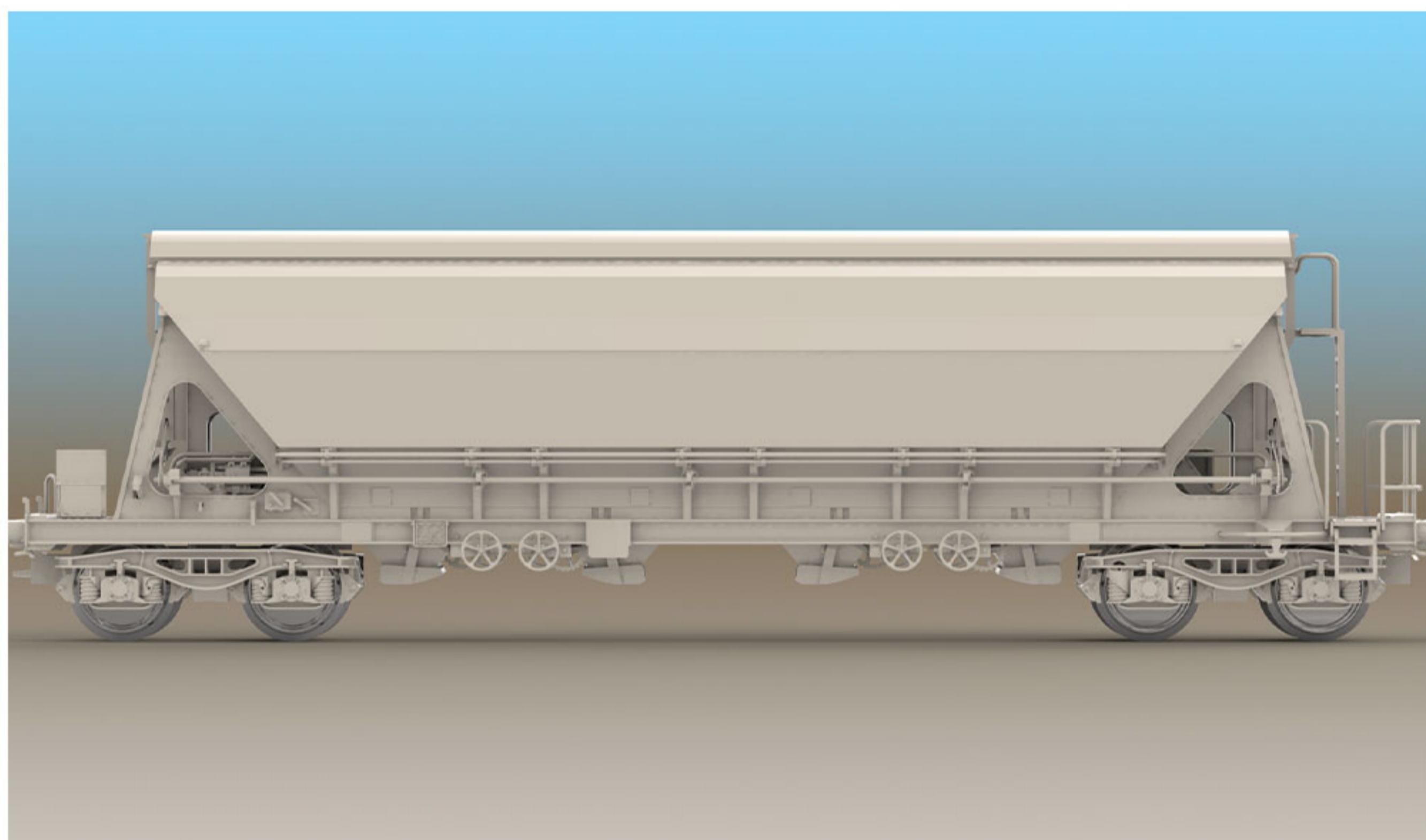

**Welded Y25 bogies** / *Bogies Y25 soudés*

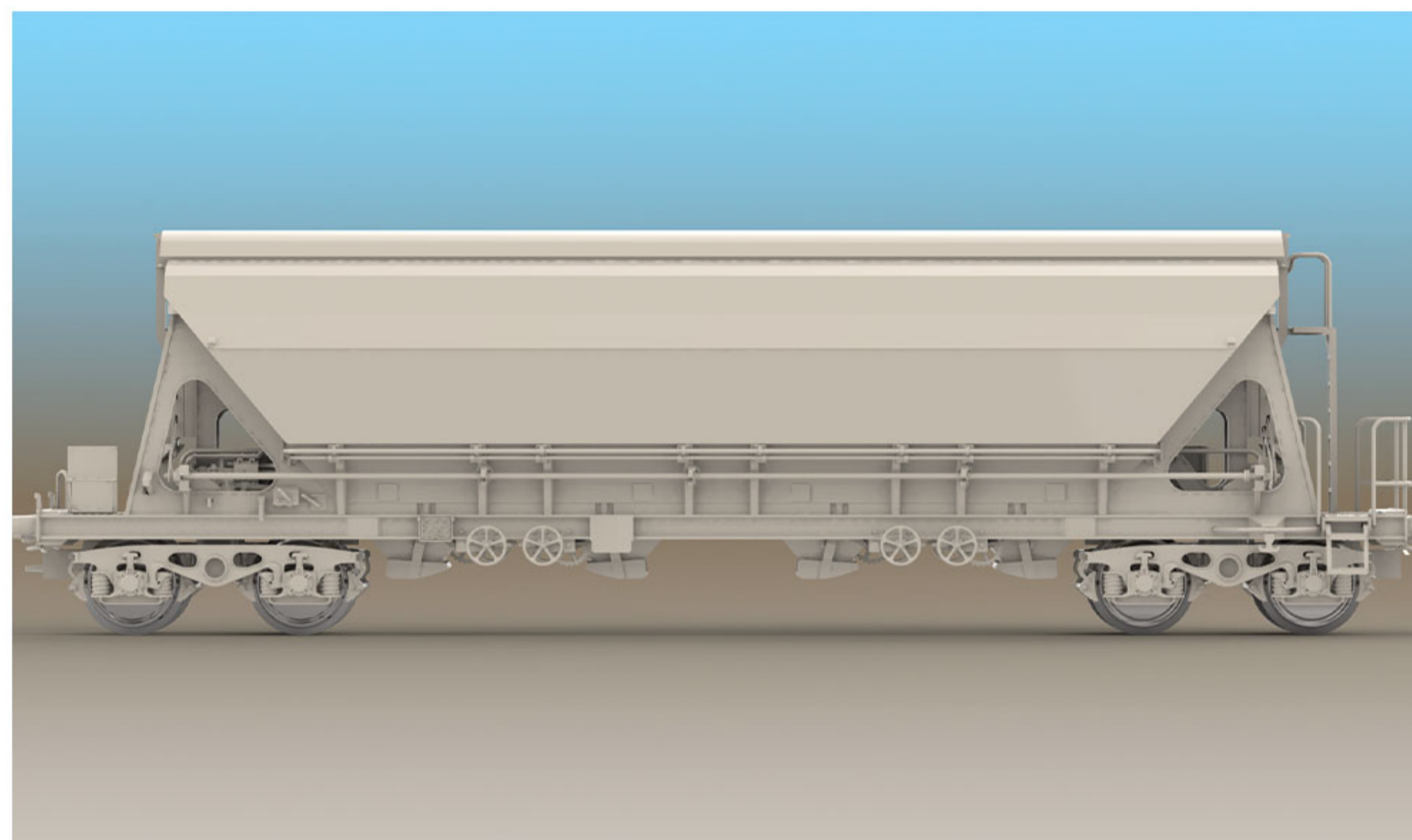

**Cast Y25 bogies** / *Bogies Y25 moulés*

## **T90**

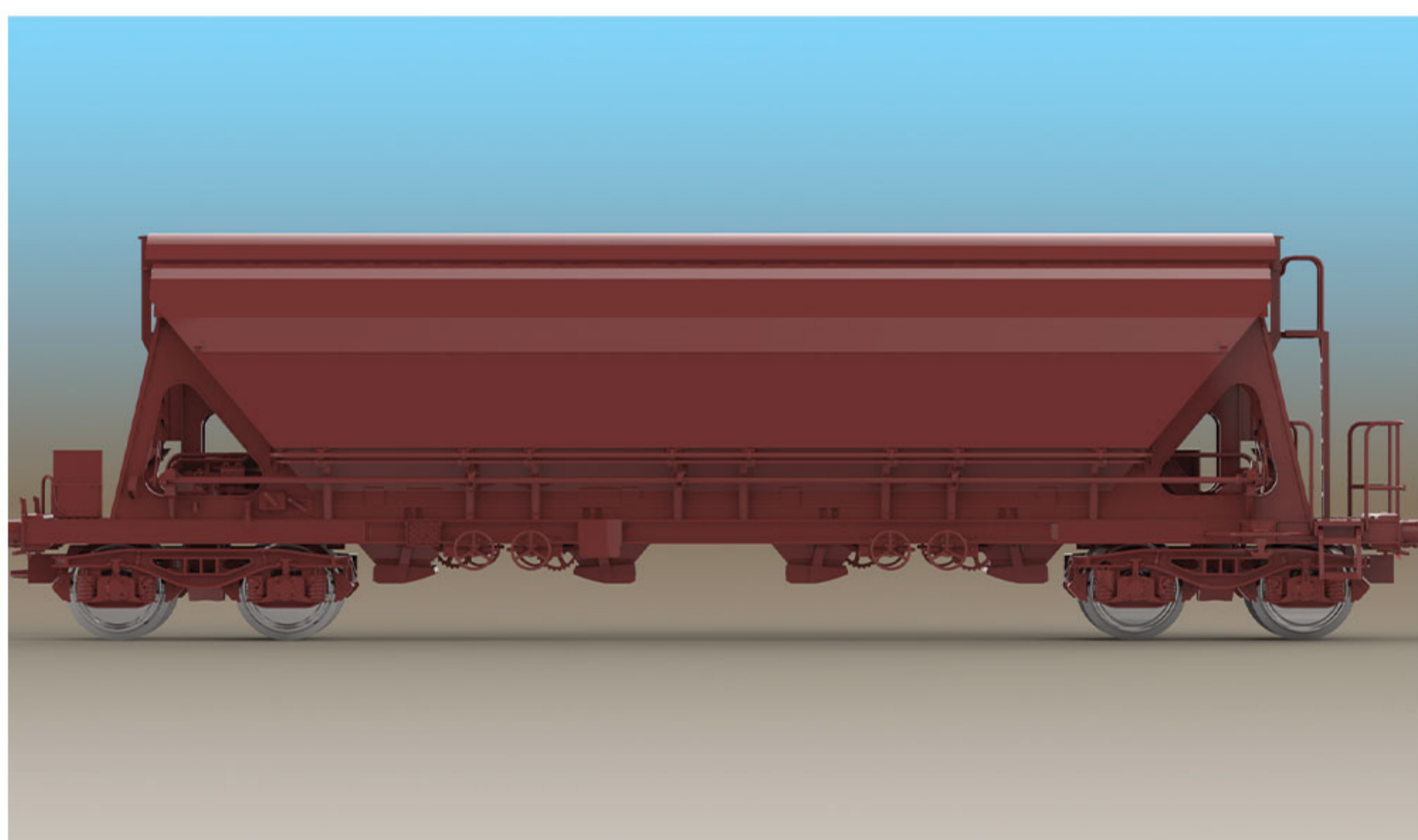

**Welded Y25 bogies** / *Bogies Y25 soudés*

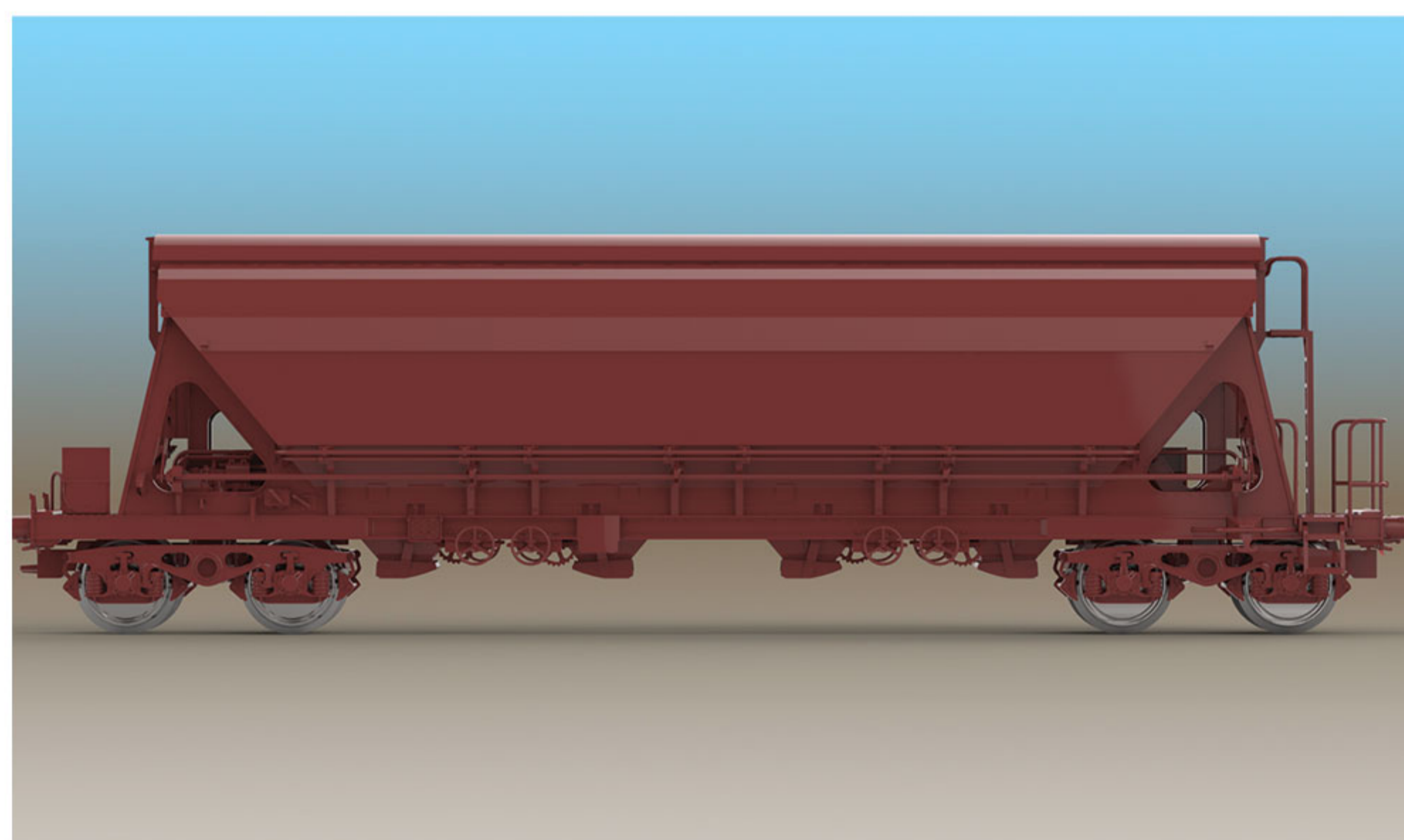

**Cast Y25 bogies** / *Bogies Y25 moulés*

## **"Sucre"**

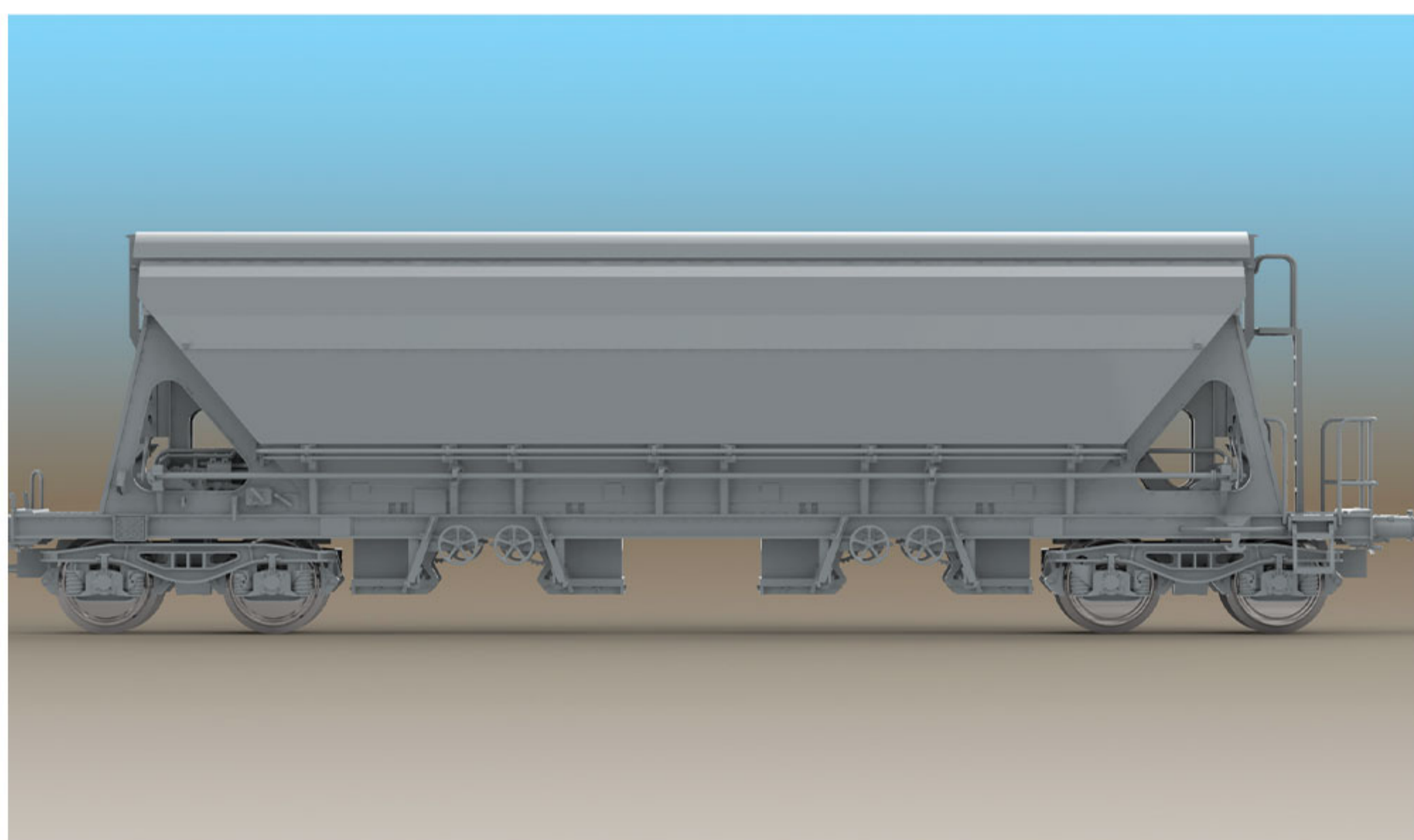

**Welded Y25 bogies** / *Bogies Y25 soudés*

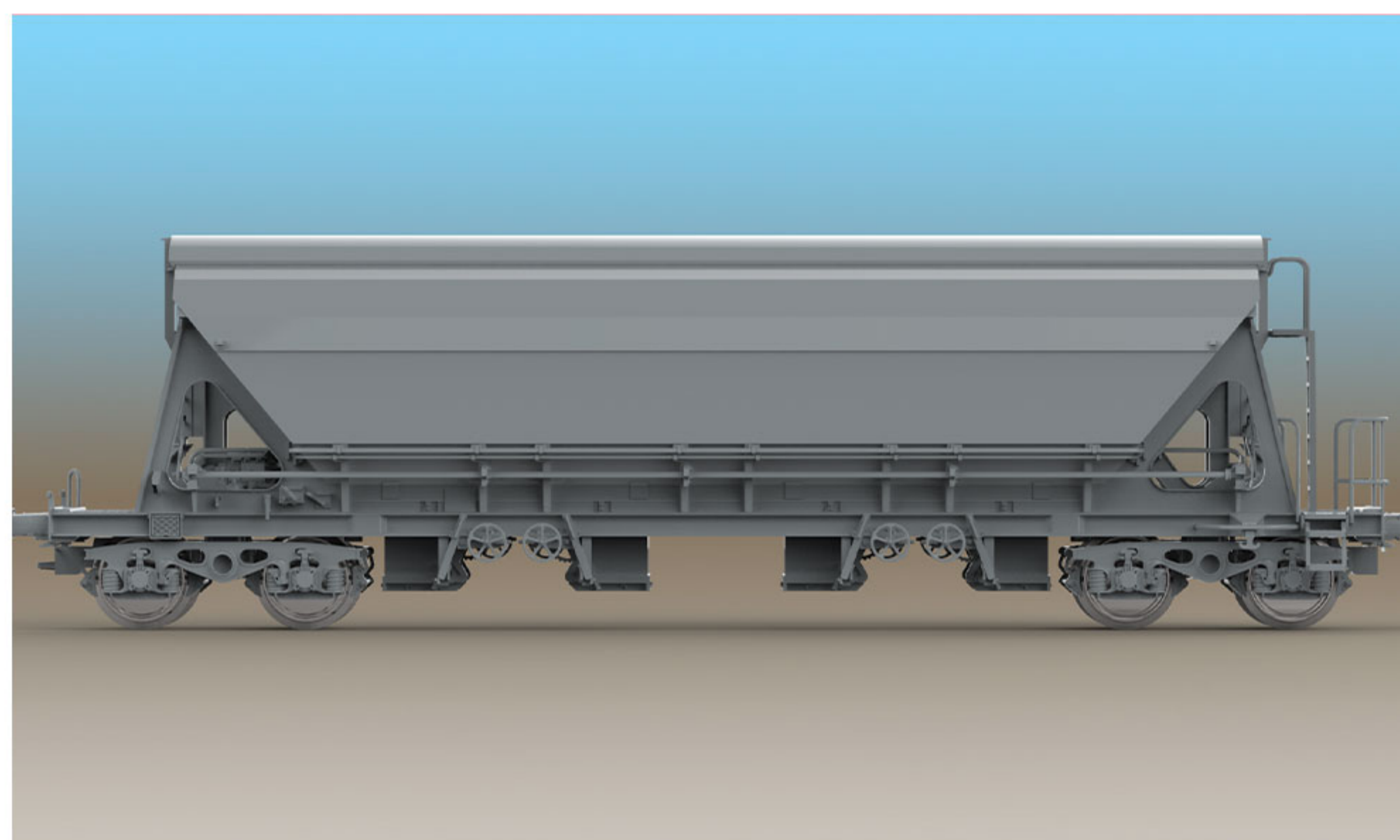

**Cast Y25 bogies** / *Bogies Y25 moulés*

**The model consists of about 160 parts**

*/ Le modèle est composé d'environ 160 pièces*

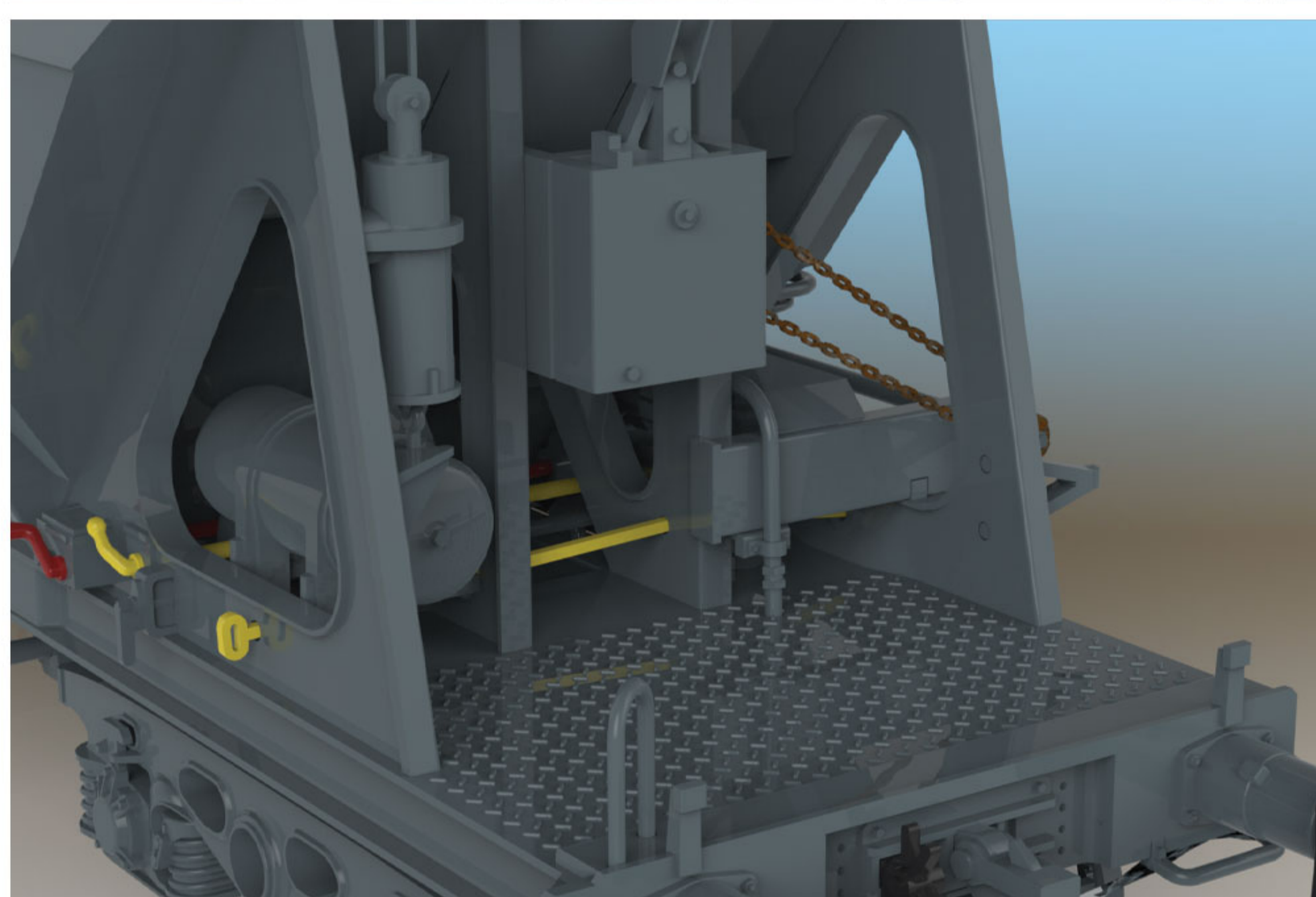
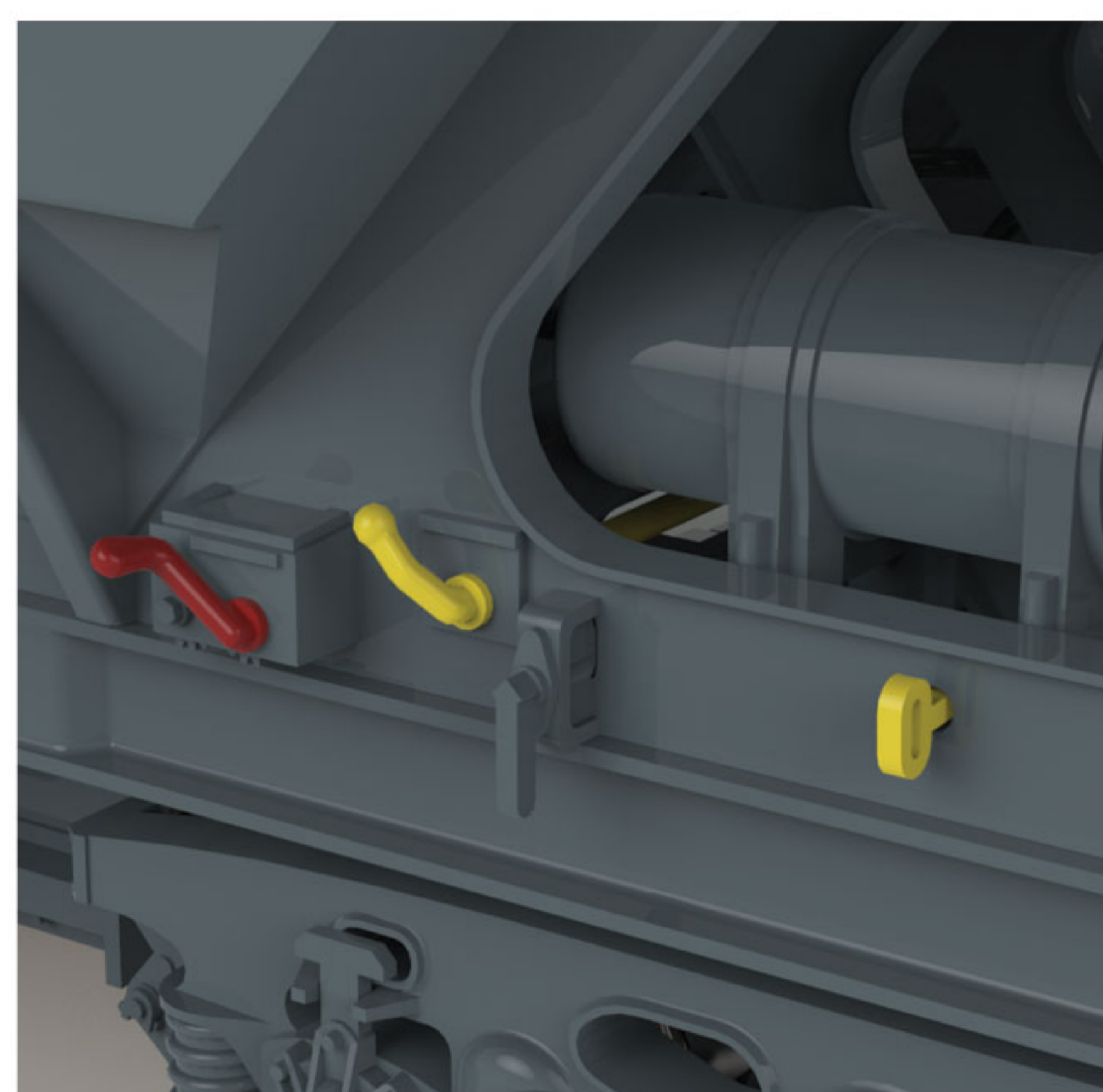
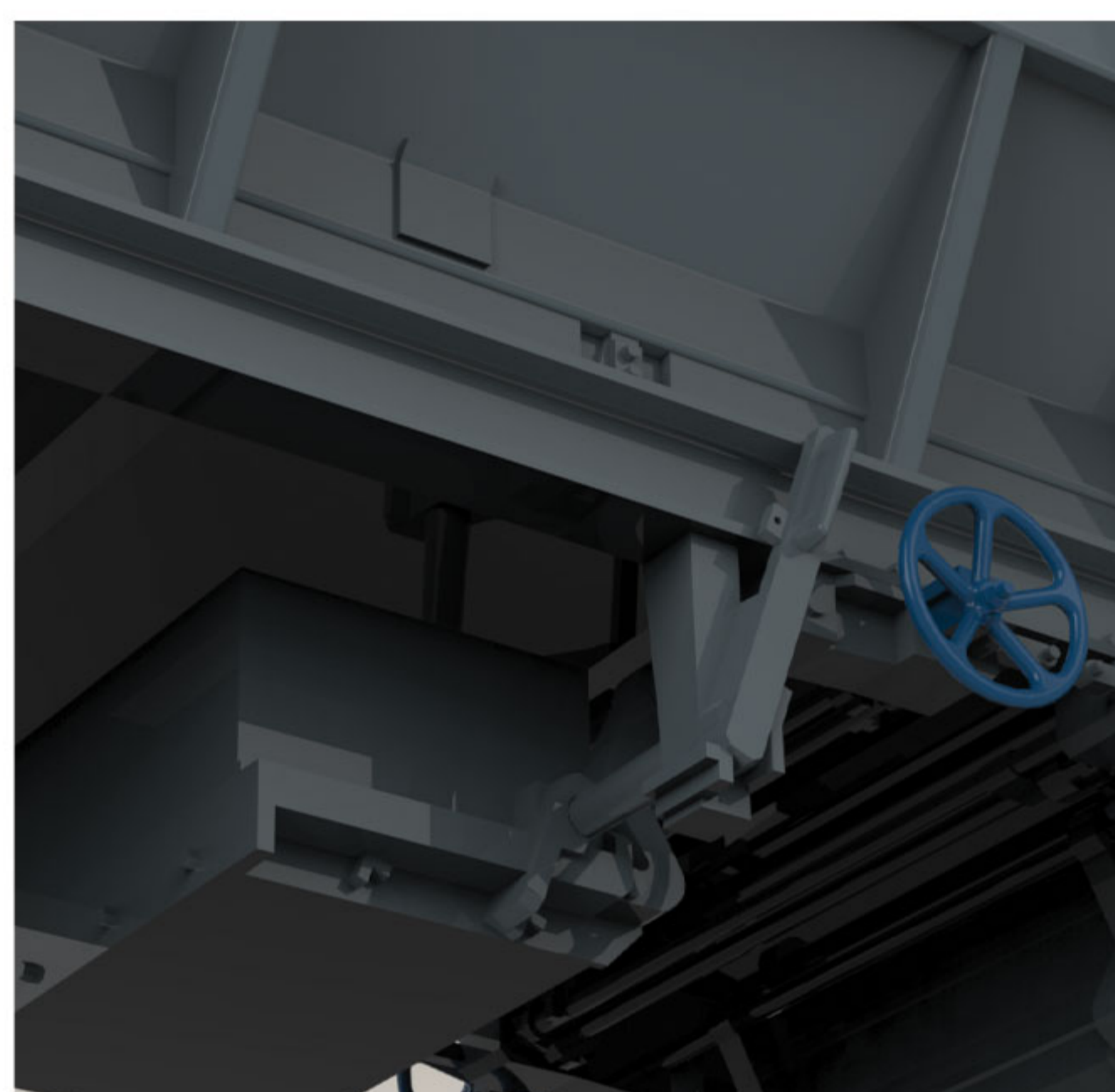
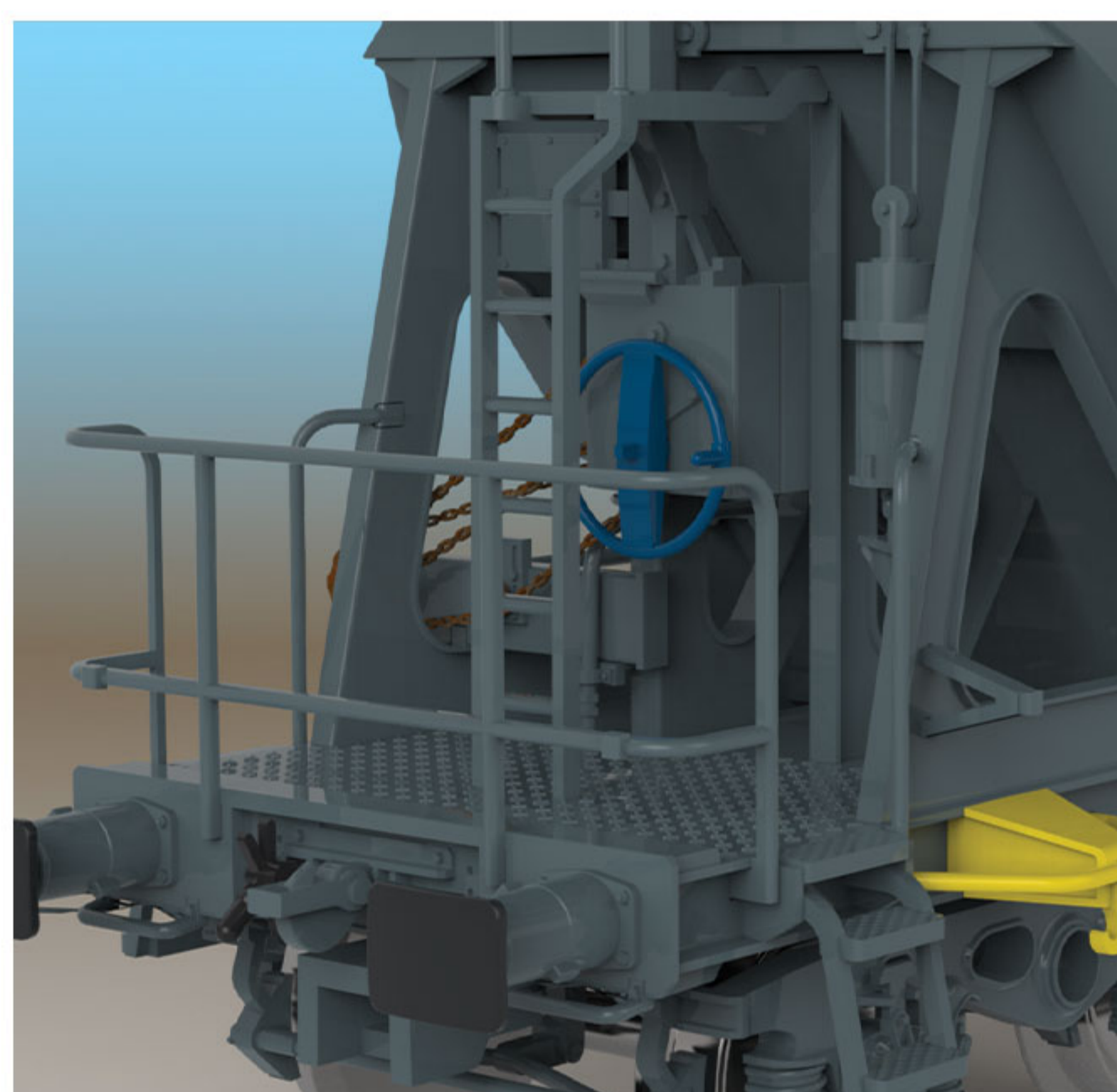
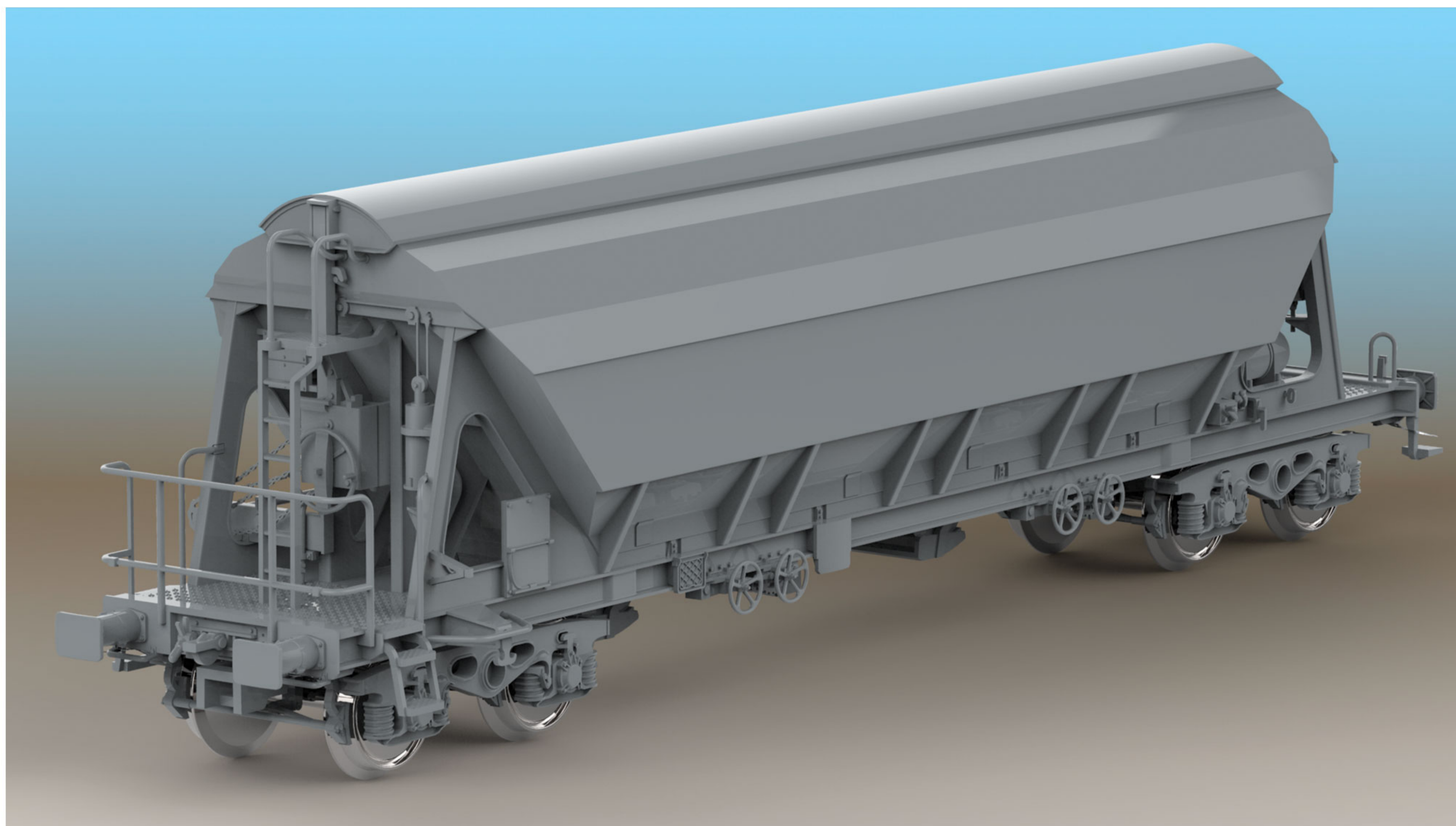

# F-CTC - "Sucre" Tapps freight wagon

France

Era: VI

Registration number : 33 87 0658 601-7

Albert Modell 065311

2-rail

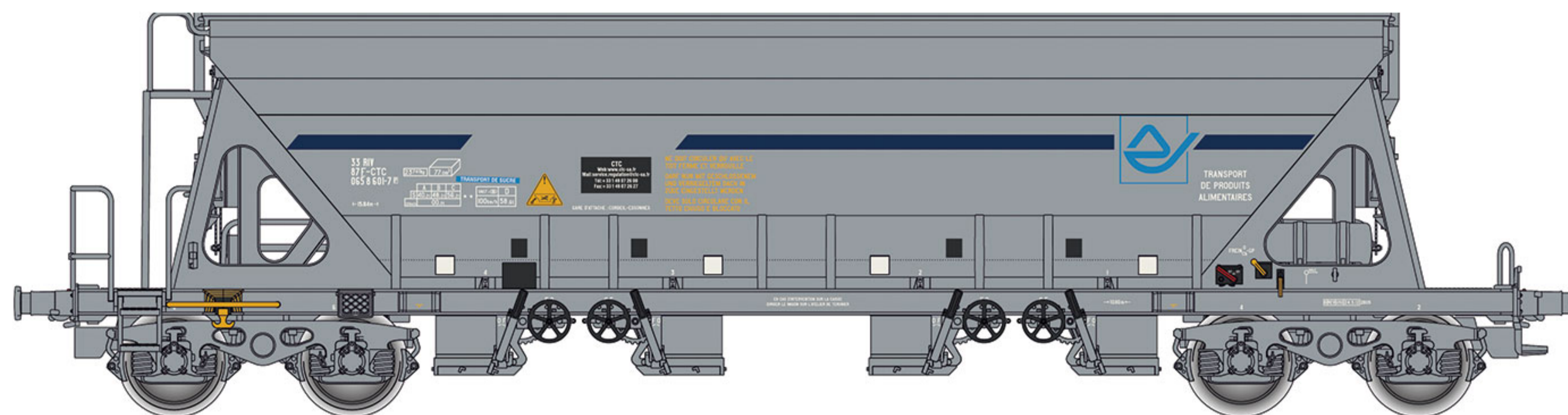

HO (1:87) | 182 mm | 358 mm | NEM 362

# F-CTC - "Sucre" Tapps freight wagon

France

Era: VI

Registration number : 33 87 0658 619-9

Albert Modell 065312

2-rail



HO (1:87) | 182 mm | 358 mm | NEM 362

# F-ERSA - Tanpps freight wagon

France

Era: VI

Registration number : 33 87 0659 064-7

Albert Modell 065313

2-rail

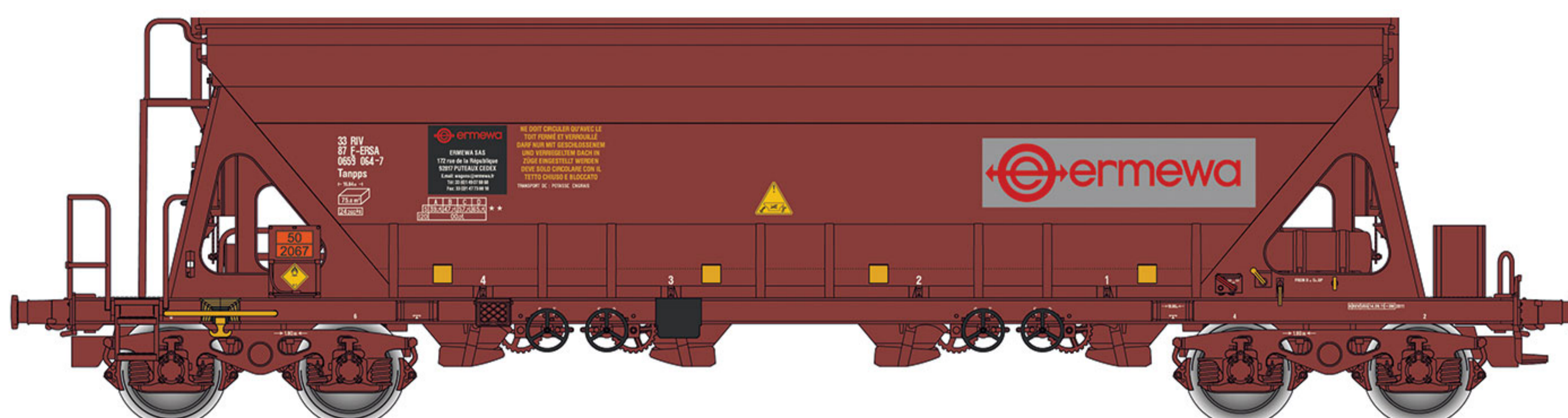

HO (1:87) | 182 mm | 358 mm | NEM 362

# F-ERSA - Tanpps freight wagon

France

Era: VI

Registration number : 33 87 0659 084-5

Albert Modell 065314

2-rail

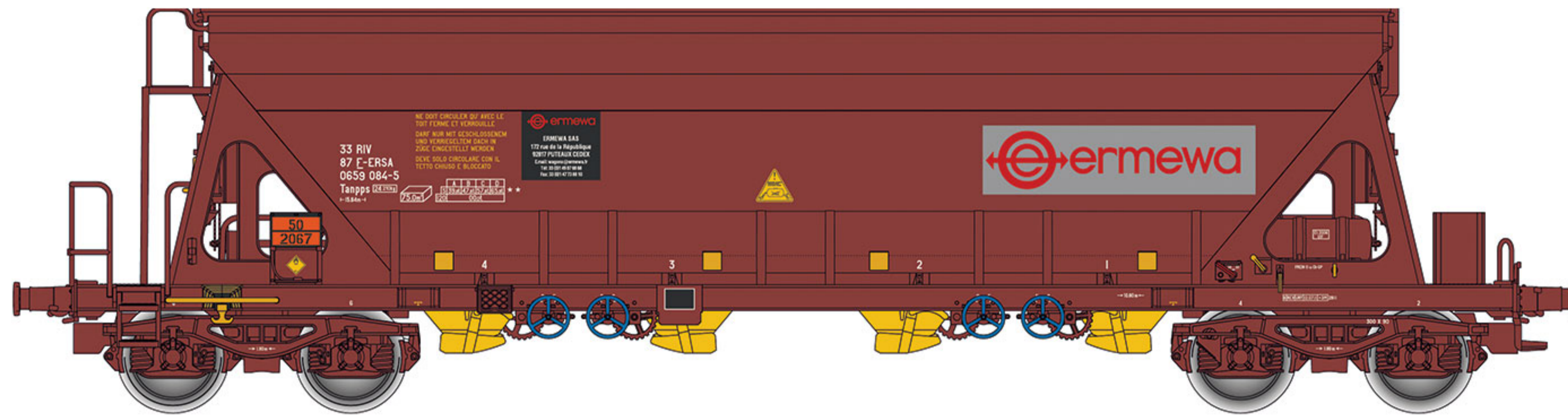

HO (1:87) | 182 mm | 358 mm | NEM 362

# F-ERSA - Tanpps freight wagon

France

Era: VI

Registration number : 33 87 0659 612-3

Albert Modell 065315

2-rail

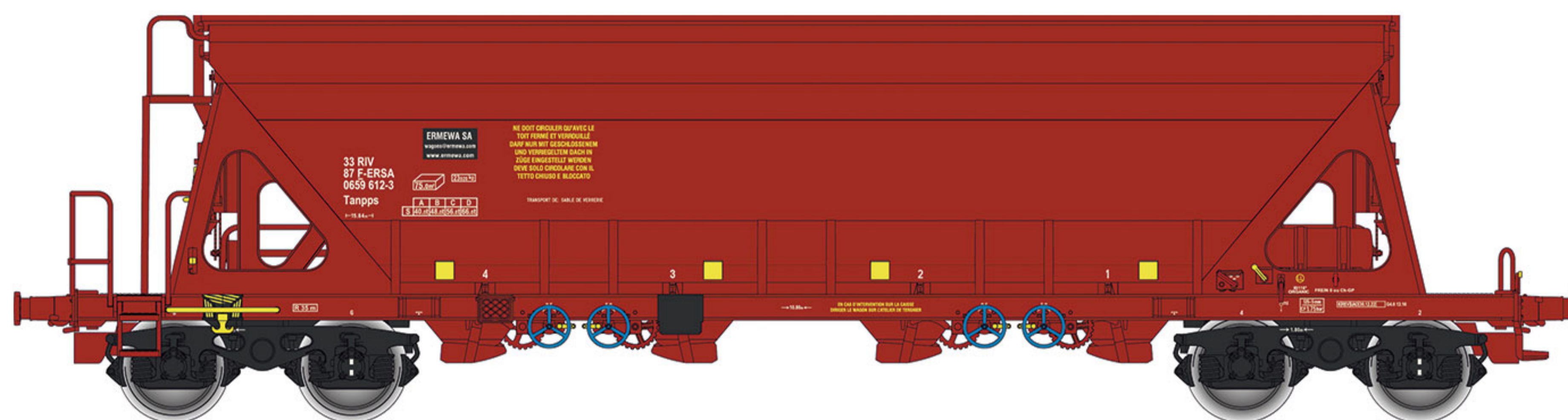

HO (1:87) | 182 mm | 358 mm | NEM 362

# F-ERSA - Tanpps freight wagon

France

Era: VI

Registration number : 33 87 0659 604-0

Albert Modell 065316

2-rail



HO (1:87) | 182 mm | 358 mm | NEM 362

# F-FW – Tapps freight wagon

France

Era: VI

Registration number : 33 87 0658 250-3

Albert Modell 065317

2-rail



HO (1:87) | 182 mm | 358 mm | NEM 362

# F-FW – Tapps freight wagon

France

Era: VI

Registration number : 33 87 0658 029-1

Albert Modell 065318

2-rail



HO (1:87) | 182 mm | 358 mm | NEM 362

# SNCF – Tanpps freight wagon

France

Era: V

Registration number : 33 87 0659 090-2

Albert Modell 065319

2-rail

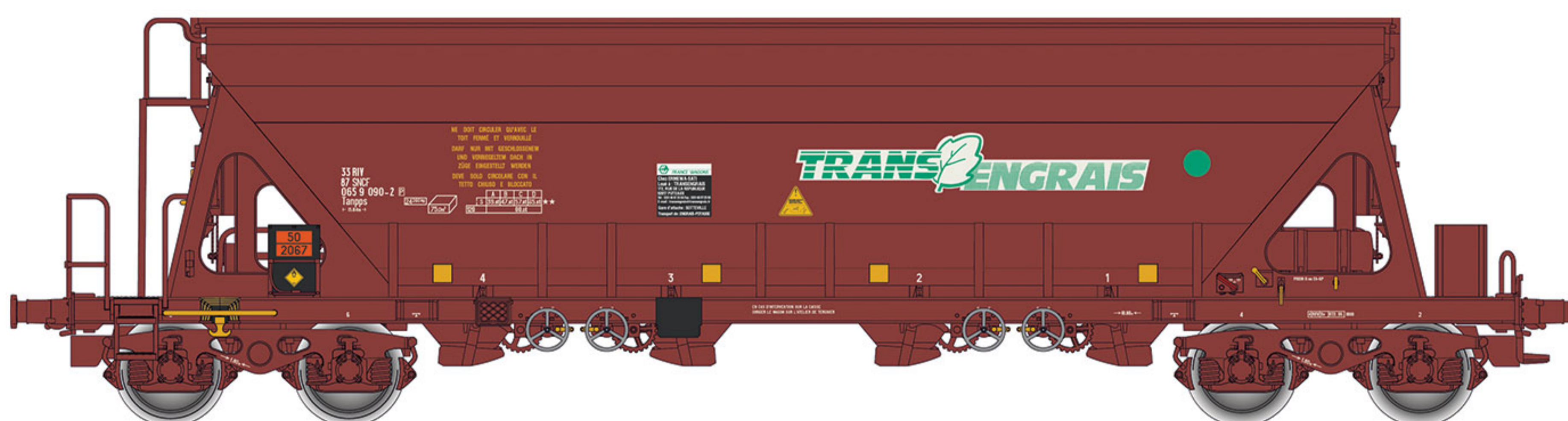

HO (1:87) | 182 mm | 358 mm | NEM 362



# SNCF - Tanpps freight wagon

France

Era: V

Registration number : 33 87 0659 128-0

Albert Modell 065320

2-rail



HO (1:87) | 182 mm | 358 mm | NEM 362

# SNCF - Tanpps freight wagon

France

Era: V

Registration number : 33 87 5659 322-0

Albert Modell 565003

2-rail



HO (1:87) | 182 mm | 358 mm | NEM 362

# SNCF - Tanpps freight wagon

France

Era: V

Registration number : 33 87 5659 212-3

Albert Modell 565004

2-rail



HO (1:87) | 182 mm | 358 mm | NEM 362

# ALBERT MODELL

About us

## The history of our company

Established in 2014, Albert-Modell has swiftly emerged as a known name in the world of model railway manufacturing. Our international presence, which commenced in 2017, marks a significant milestone in our journey. At Albert-Modell, our primary focus rests on producing exquisitely detailed models of Eastern European freight wagons, alongside an impressive range of diesel locomotives, but our range includes more and more models from countries like Germany and Switzerland.

Our philosophy is anchored in the belief that model-making is an art that demands precision, detail, and affordability. We strive to blend these elements, offering our clients high-quality, intricately designed models at a price that respects their passion and investment in this hobby.

Our products are crafted not merely as toys, but as collectibles, with a dedication to craftsmanship.

We pride ourselves on producing models in limited quantities, ensuring that each piece we create is not just a model but an elegant representation of the original. This approach underlines our commitment to quality over quantity, making our models sought-after items for collectors and enthusiasts who value exclusivity and authenticity.

À propos de nous

## L'histoire de notre entreprise

Fondée en 2014, Albert-Modell s'est rapidement imposée comme un nom reconnu dans le monde de la fabrication de trains miniatures. Notre présence internationale, commencée en 2017, marque une étape importante dans notre parcours. Chez Albert-Modell, notre objectif principal est de produire des modèles extrêmement détaillés de wagons de marchandises d'Europe de l'Est, ainsi qu'une gamme impressionnante de locomotives diesel, mais notre gamme inclut de plus en plus de modèles de pays comme l'Allemagne et la Suisse.

Notre philosophie repose sur la conviction que la modélisation est un art qui exige précision, détail et accessibilité. Nous nous efforçons de combiner ces éléments, offrant à nos clients des modèles de haute qualité, finement conçus, à un prix qui respecte leur passion et leur investissement dans ce loisir. Nos produits ne sont pas simplement des jouets, mais des objets de collection, avec un dévouement à l'artisanat.

Nous sommes fiers de produire des modèles en quantités limitées, garantissant que chaque pièce que nous créons n'est pas seulement un modèle, mais une représentation élégante de l'original. Cette approche souligne notre engagement envers la qualité plutôt que la quantité, faisant de nos modèles des objets recherchés par les collectionneurs et les passionnés qui apprécient l'exclusivité et l'authenticité.

**TD** TrainsDepot.org

**We highlight your miniatures**

© 2024 TrainsDepot.org - All right reserved

Felvidéki u. 8, Komárom,  
H-2900 - Ungarn

[info.albertmodell@gmail.com](mailto:info.albertmodell@gmail.com)  
[www.albertmodell.com](http://www.albertmodell.com)